

HZ160/160J

SELF-PROPELLED ARTICULATED BOOMS

Mantall®

Standard Features

- Self-leveling platform
- Hydraulic rotation platform
- Hall effect fully proportional controls
- Driving confirm
- AC wiring to platform
- Horn
- Hour meter
- Tilt alarm
- Positive traction drive
- Dual Speed motor
- Emergency pump
- CAN intelligent control
- Overload Sensor

Options Features

- Platform swing gate
- Platform alternate leverage
- Airline to platform
- Hydraulic oil cooler
- Hostile environment packages
- Anti-crash air packages
- Tool tray
- Alarm packages
- Platform work lights



HZ160RT/160JRT

MODEL	HZ160RT	HZ160JRT
Max. Working height	16 m	
Max. Platform height	14 m	
Max. Outreach	8.19 m	8.4 m
Max. Up and over clearance	7.09 m	7.71 m
Max. Lift capacity	230 kg	
Platform size B x C x A	1.8 x 0.76 x 1.17 m	
Height - stowed D	2.3 m	
Length - stowed E	6.14 m	6.87 m
Width F	2.00 m	
Wheelbase G	2.00 m	
Ground clearance H	0.36 m	
Turntable rotation	360° discontinuously	
Turntable tailswing	0	
Platform rotation	0 / 180°	
Jib Swing	0/140°(HZ160JRT only)	
Platform Level	Hydraulic level	
Drive speed - stowed	4.9km/h (7.0km/h 4wd)	
Drive speed - raised	1.0km/h	
Gradeability	30% (45%4WD)	
Max. tilt angle	3°	
Max. lateral force N	400 N	
Max. Wind speed allowed	12.5 m/s	
Min. Turning radius-(inside)	1.7 m	
Min. Turning radius-(outside)	4.0 m	
Drive wheels number	2 / 4 WD	
Steering wheel number	2	
Controls	Electrical proportional control	
System voltage	DC 12V	
Hydraulic tank capacity	70 L	
Fuel tank capacity	65 L	
Tire size	33 x 12 - 20	
Power	Perkins 404D Diesel Engine	
Total weight	6.35 t	6.8 t

Range of motion HZ160RT

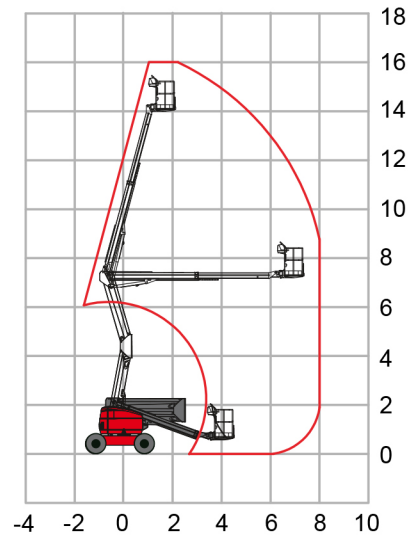

Range of motion HZ160JRT

